

900 & 920 HAMEL ROAD
 PROPERTY AREA = 2.06 ACRES
 ZONING - COMMERCIAL-GENERAL/SHORELAND OVERLAY

Property Description:
 Lots 4, 5, and 6, MEDINA CREEKSIDE ADDITION, Hennepin County, Minnesota, according to the recorded plat thereof.

- NOTES:
1. DIMENSIONS MEASURED OFF THE PROPERTY LINES ARE PERPENDICULAR TO THEM.
 2. REFER TO ARCHITECTURAL PLANS PREPARED BY VANMAN ARCHITECTS & BUILDERS, INC FOR BUILDING INFORMATION & DIMENSIONS.
 3. REFER TO SURVEY JOB NUMBER 17-0504 PREPARED BY OTTO ASSOCIATES, INC. FOR ADDITIONAL BOUNDARY INFORMATION.

- LEGEND**
- FF=989.36 denotes Finished Floor Elevation
 - ⊕ denotes Gas Meter
 - ⊕ denotes Telephone Pedestal
 - ⊕ denotes Electrical Box
 - ⊕ denotes Light Pole
 - ⊕ denotes Flag Pole
 - ⊕ denotes Sign
 - ⊕ denotes Water Valve
 - ⊕ denotes Gas Valve
 - ⊕ denotes Hydrant
 - SS denotes Existing Sanitary Sewer Line
 - ST denotes Existing Storm Sewer Line
 - GAS denotes Existing Gas Line
 - denotes Drainage and Utility Easement per the plat MEDINA CREEKSIDE ADDITION
 - denotes Building Setback Line
- Front = 25'
 Side = 10'
 Rear = 20'

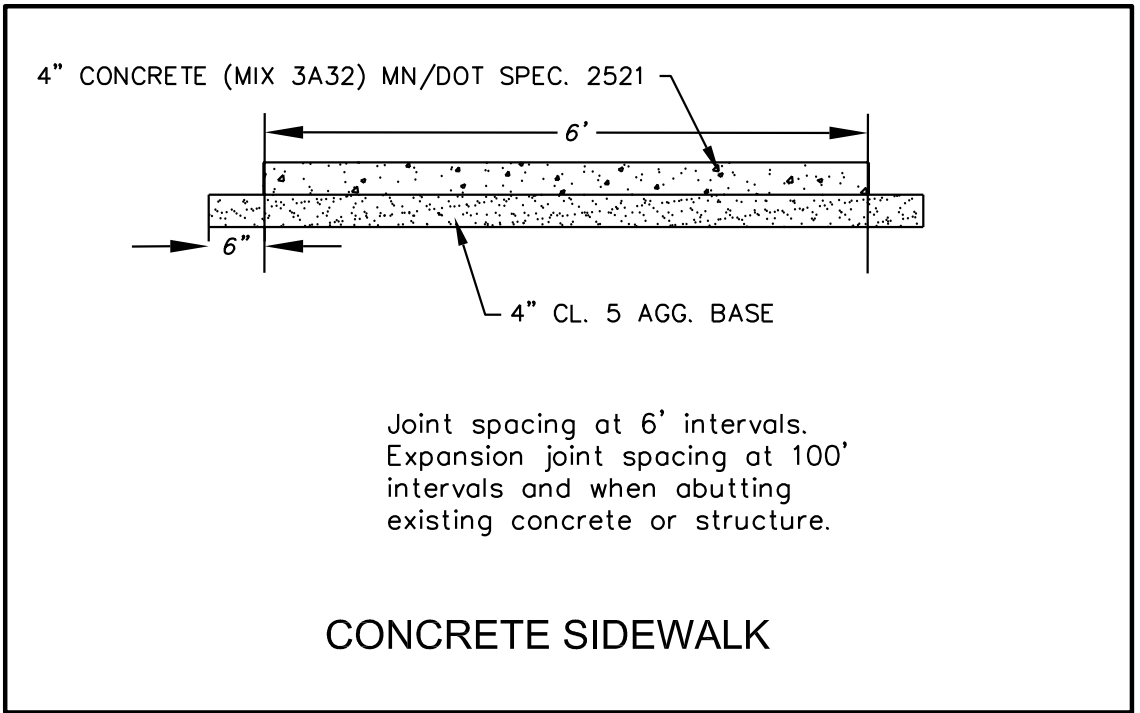
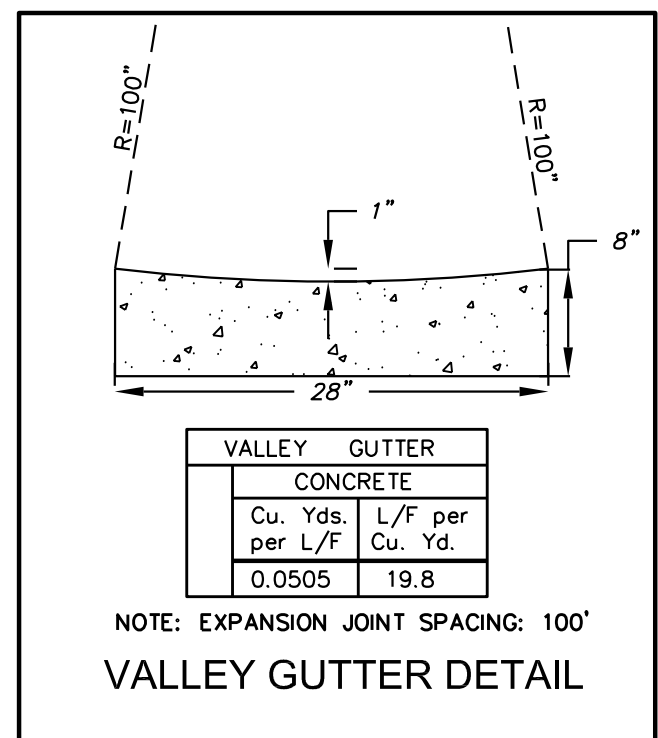
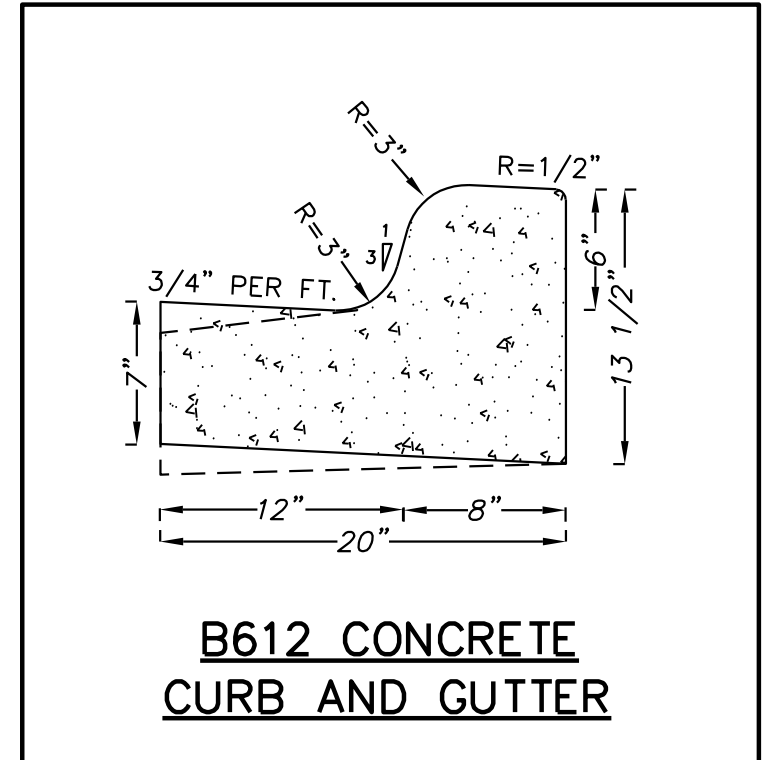

EXISTING HARDCOVER CALCULATIONS:

Area =	89,518.40	S.F.
EXISTING BUILDING (NORTH)	12,658	S.F.
EXISTING BUILDING (SOUTH)	5,976	S.F.
COVERED ENTRANCE (NORTH)	103	S.F.
COVERED ENTRANCE (SOUTH)	84	S.F.
EXISTING BITUMINOUS	22,198	S.F.
EXISTING CONCRETE	3,957	S.F.
TOTAL	44,976	S.F.
% HARDCOVER	50.2	%

PROPOSED HARDCOVER CALCULATIONS:

Area =	89,518.40	S.F.
EXISTING BUILDING (NORTH)	12,658	S.F.
EXISTING BUILDING (SOUTH)	5,976	S.F.
NEW BUILDING ADDITION	3,845	S.F.
COVERED ENTRANCE (NORTH)	103	S.F.
COVERED ENTRANCE (SOUTH)	84	S.F.
EXISTING BITUMINOUS	17,434	S.F.
EXISTING CONCRETE	2,119	S.F.
NEW BITUMINOUS	3,407	S.F.
NEW CONCRETE	668	S.F.
TOTAL	46,294	S.F.
% HARDCOVER	51.7	%

REV. NO.	DATE	BY	DESCRIPTION
1	12/13/17	CSO	REVISED PER CITY REVIEW
2	02/25/19	EMS	ADD STORM SEWER & PAVEMENT; REMOVE GRASSPAVE & BIT. TO BLDG ADDITION; REVISE HARDCOVER CALCS
3	02/11/19	CSO	REVISE HARDCOVER CALCS
4	03/20/19	CSO	REVISE BUILDING, EAST PARKING EDGE, SAND BIN & HARDCOVER CALCS

DESIGNED DRAWN
 CSO CSO

CHECKED

I hereby certify that this plan, specification, or report was prepared by me or under my direct supervision and that I am a duly Licensed Professional Engineer under the laws of the State of Minnesota.

Caro M. Schwahn
 Caro M. Schwahn Otto
 License # 40433 Date: 3/20/19

OTTO ASSOCIATES
 Engineers & Land Surveyors, Inc.

www.ottoassociates.com
 9 West Division Street
 Buffalo, MN 55313
 (763) 682-4727
 Fax: (763) 682-3522

MAXXON CORPORATION
VANMAN ARCHITECTS & BUILDERS, INC.
 MEDINA, MN

SITE PLAN

SHEET NO. C1 OF C2 SHEETS

PROJECT NO: 17-0504
 DATE: 11/13/17